

THE PILOT MODEL BALKED LANDING SIMULATION PROJECT:
A GOVERNMENT, INDUSTRY AND NATIONAL RESEARCH COOPERATION

Ruud Hosman, AMS Consult, Delfgauw, the Netherlands¹

Jan Schuring and Peter van der Geest, National Aerospace Laboratory NLR, Amsterdam, the Netherlands

Andy Belyavin, QinetiQ, Farnborough, Hants, UK

Greg Robel, Boeing Phantom Works, Seattle, USA

John M. Towler, Boeing Commercial Airplanes, Seattle, USA

Hans J. Hörmann, Boeing Research & Technology Europe, Madrid, Spain

Abstract

The introduction of New Larger Aeroplanes presents the ICAO Obstacle Clearance Panel (OCP) with the need to review the requirements for the Obstacle Free Zone. To support future decisions, the OCP took the initiative to begin the development of pilot models able to control the simulated aircraft during the approach – go-around manoeuvre. The aim of this development was to obtain a tool to perform Monte Carlo simulations for the determination of the flight path statistics of the manoeuvre.

In 2001, both QinetiQ and the National Aerospace Laboratory (NLR) were invited to develop pilot models. The two pilot models are based on fundamentally different descriptions of a pilot's control behaviour. The QinetiQ pilot model is based on a discrete-event representation of pilot control movements and has been developed in the Integrated Performance Modelling Environment (IPME). The NLR pilot model is based on control engineering and is a linear model with visual and motion feedback, extended with stochastic disturbances.

This development was supported by Boeing, which provided a simulation model of the B747-400 as the representative aircraft model. The integration of the pilot models with the aircraft model was performed by Boeing. Statistical data on the flight path tracking during the approach – go-around manoeuvre and on discrete pilot actions were obtained from simulations performed in a full flight simulator at NASA Ames and a fixed base simulator at Boeing.

Both pilot models, the use of the statistical data from the simulations and the integration with the aircraft model are discussed in the paper.

Introduction

With the introduction of so-called New Larger Aeroplanes (NLA) in the near future, attention has to be given to the subject of pilot/aircraft performance during bailed landings. A bailed landing is an approach to land, which is aborted in a very late phase of the landing; e.g.. at a height below 50 ft. The need to address this issue arises from questions concerning the dimensions of the Obstacle Free Zone (OFZ) that is required to accept the operation of the NLA at given aerodromes. As currently addressed in the ICAO Obstacle Clearance Panel it needs to be established whether the OFZ, as specified for the largest category of aircraft (code F, ICAO Annex 14) is appropriate for the near term introduction of the NLA.

It should be noted that the definition of the OFZ in the past has been based on aircraft equipped with significantly less advanced technologies (both in aircraft performance and systems) than current generation of new aircraft. If the current specification of the OFZ would be overly conservative, it might unduly restrict the introduction of the NLA at certain aerodromes, or vice versa may require unnecessary investments for aerodromes to allow the introduction of the NLA.

In order to address this problem, the ICAO Obstacle Clearance Panel took the initiative to ask for a quantitative (probabilistic) safety assessment. The ICAO, the national aviation authorities and the aeroplane industry (Refs. 1, 2 and 3) supported this initiative. In this way the level of safety provided by the OFZ can be established, and compared with a given target level of safety.

Besides the bailed landing following an automatic approach, the OCP also asked for an analysis of the manually-flown bailed landing following a flight director approach. The Flight Operations and

¹ r.hosman@amsconsult.demon.nl

Analysis Branch of the FAA offered to support this effort by the use of the Airspace Simulation and Analysis Tool (ASAT) to perform the analysis (Ref. 3). For this purpose, sufficiently reliable and accurate aircraft and pilot models need to be developed. Today the state-of-the-art modelling techniques are largely developed to a level that these models can be provided. Since no validated aircraft models for the NLA were available. The Boeing Company made the aircraft model of the B747-400 available for this study.

The OCP asked for the independent development of two pilot models based on different principles. For this purpose QinetiQ at Farnborough in the UK (Ref. 4) and the National Aerospace Laboratory in Amsterdam (Ref. 5) were invited to provide their expertise to develop the pilot models. The aim for these models is that they can simulate pilots' control behaviour during the approach to land followed by a bailed landing under a range of configurations (centre of gravity, weight and flap setting), atmospheric conditions (wind, gust and visibility) and can capture the effects of pilot variability. To support the development of the pilot models a simulation of the closed loop of the pilot and aircraft model was required. For this purpose, Boeing Seattle developed a simulation of the B747-400, representing the characteristics of a NLA, including reduced aerodynamic model, engines, flight control system, flight director, and yaw damper (Ref. 6). This model was implemented in the MSC Engineering Analysis System (EASY5) environment and made available to QinetiQ and NLR. After the goal of the pilot models has been satisfied, the pilot models will be integrated into the ASAT to perform Monte Carlo simulations. The results of these simulations will be used to determine the OFZ.

In addition to this effort, manned simulations of the bailed landing to generate a data base of performance data were performed in the fixed base B747-400 simulator at Boeing and the B747-400 FFS at NASA Ames. The purpose of the database is to provide data on rule and skill based pilot behaviour to support the evaluation and fine-tuning of the pilot models. To this end an extensive statistical analysis of the database has been carried out (Ref. 7).

Finally, the Central Aerohydrodynamic Institute (TsAGI) in Moscow was invited to evaluate the final pilot models to assure that the functioning of the pilot models in the process to derive the OFZ satisfies the safety requirements (Ref. 8).

In this paper, the general background and requirements of pilot model development for the

bailed landing study, the required development environment and the statistical analysis of simulator data are discussed. Thereafter, the specific characteristics of the QinetiQ and NLR pilot models are explained and results shown. The paper will be closed with a discussion and conclusions.

Background and requirements for the pilot model development

The pilot's task in a modern transport aircraft represents more and more that of a management task (hence supervisory control) than of manually controlling a dynamic system. As a supervisory controller, the pilot directs and/or controls the different aircraft systems and is free to decide which part of the task should be performed manually and which part by the automatic systems. Rasmussen (Ref. 9), in an attempt to structure human operator behaviour, classified this behaviour into three levels: skill-based, rule-based and knowledge-based behaviour, Fig. 1.

At the skill-based level, the perceptual-motor system acts as a continuous control system. The inputs to

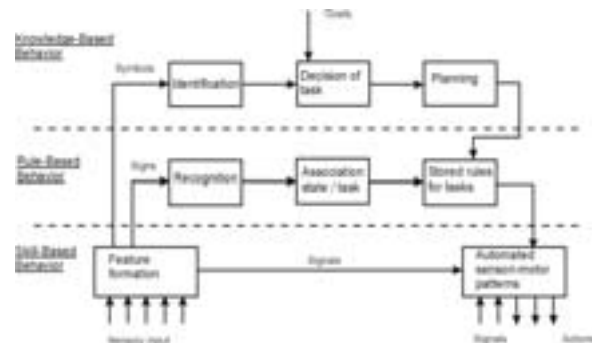

Figure 1. Simplified scheme of the three levels of behavior of the human operator (Ref 9).

the sensors, in this case the visual system, the vestibular system, proprioceptive system, etc., are perceived as continuous *signals* as a function of time and used to generate the control output.

At the rule-based level, the perceived stimuli are considered as *signs*, marking changes in conditions and/or procedure. Based on the signs, the new rule is selected. After selection of the rule, the execution is performed with the learned sensory-motor patterns; i.e., skill-based behaviour.

Functional reasoning to predict future changes or behaviour of the environment is based on *symbols* at the knowledge-based level.

Thus, knowledge-based behaviour is based on a cognitive understanding of the particular task and results in conscious logical decisions; rule-based behaviour is based on rules and procedures; skill-based behaviour is generated by trained sensory-motor patterns. When this classification is applied to the pilot's behaviour, a better understanding of how the pilot model for the balked landing may be developed is obtained.

During the manually controlled balked landing manoeuvre the pilot generates control input to the aircraft at the skill-based level and takes discrete actions at the rule-based level. The pilot models developed at QinetiQ and NLR deal with the control behaviour at the skill-based level. Rule-based behaviour will be based on the statistical analysis of the flight simulator data obtained during balked landing manoeuvre simulations. See the section "Statistical analysis of flight simulator data" below and Ref. 7.

Where the procedure for the manual approach and go-around manoeuvre is fully described and no exceptional deviation can be modelled, knowledge based behaviour is not considered in this modelling effort.

The original request from the ICAO Obstacle Clearance Panel was to develop a pilot model, which should be able to simulate a pilot's manual control of the aircraft through the whole balked landing manoeuvre based on the Flight Director commands (Refs. 10, 11). The manoeuvre should start at a distance of 8.15 km from the runway threshold (corresponding with about 1400 ft on the ILS approach path) and end at climbing through 400 ft after initiating the go-around.

Given, however, the differences in design philosophy of the New Larger Aeroplane manufacturers, it was decided to incorporate a visual segment into the manoeuvre starting at or above the decision height. This meant that also the initiation of the flare and the de-crab should be based on the pilot's visual perception of the aircraft position relative to the runway. Consequently, the pilot model should correct the aircraft position based on the visual cues from the outside world starting at or above decision height and resuming control based on Flight Director commands after the go-around initiation. Accordingly, the go-around manoeuvre controlled by the pilot model has been divided into five segments:

1. Flight Director approach down to ≥ 200 ft
2. Visual segment down to flare and de-crab initiation

3. Flare and de-crab
4. Pitch attitude rotation and re-crab after go-around initiation
5. Flight Director climb out

In addition, the pilot models for these segments incorporate speed/thrust control for segments 1 and 2. For all segments it was assumed that the deviations from the intended path are small such that the pilot models for symmetric and asymmetric control of each segment are independent. So, pilot model parameters for symmetric and asymmetric control can be adjusted independently. The results of the statistical analysis (Refs. 7 and 12) performed on the manned simulation data show that the flare and de-crab are initiated at different instances.

Pilot model development environment

The "truth model" for the development of our B747-400 model is Boeing's proprietary, high fidelity B747-400 Integrated Aircraft Configuration (IAC) simulation. (For convenience, in the sequel reference will be made to it as the "full-fidelity simulation.") This simulation runs on HP-UX and Power PC platforms. It is the simulation which Boeing uses to conduct analyses in support of certification, accident investigation, and other critical activities. It is also the final destination for the pilot models being developed by the NLR and QinetiQ, and the ultimate environment in which to perform their final calibration. When the calibration of the pilot models has been completed in the B747-400 IAC, it will then be used, together with the pilot models, by the FAA to conduct Monte Carlo studies of balked landings in order to establish the requirements for the obstacle-free zone for new larger aeroplanes.

Although the B747-400 IAC is the most fully elaborated and most extensively validated simulation of a large commercial aeroplane available, it was decided that it would not provide a convenient vehicle for the researchers at the NLR and QinetiQ to use in their pilot model development. For one thing, it is available only on certain platforms, as already noted. More importantly, the full-fidelity simulation does not support some of the most useful and widely-used techniques in control system engineering; namely, the generation of a linearised system model in the vicinity of an equilibrium point, and the subsequent use of the linearised model for control system analysis and design.

For these reasons, it was decided to implement a simplified B747-400 model in MSC.EASY5™, a

commercial software package for the modelling, simulation, and analysis of dynamical systems. MSC.EASY5 was chosen since it was readily available, we were familiar with it and with its capabilities (it was originally developed at Boeing), and we were confident of its suitability for "industrial-strength" applications. MSC.EASY5 allows one to build a system model graphically, by means of a block diagram. The basic elements of the block diagram can be either members of standard component libraries supplied by MSC.EASY5, or customised blocks of C or Fortran code created by the user. Component libraries are available for "generic" dynamical system elements (transfer functions, summing junctions, various "standard" non-linearities, etc.) as well as for variety of specific application domains, including aerospace vehicles, thermal hydraulics, multi-phase fluids, and several others. Any portion of the block diagram can be "collapsed" into a submodel, and submodels can be nested hierarchically.

Once the user has completed the construction of the block diagram for his model, he can then direct MSC.EASY5 to generate executable code for the model. To simplify matters slightly, the block diagram represents a system of ordinary differential equations. The dependent variables in these equations form the components of the *state vector*. The executable code evaluates the derivative of the state vector. This derivative is a function of the current value of the state vector, of the exogenous inputs into the system (if any), and (possibly) of time.

Once the user has generated the executable code for his model, the model may be simulated by using any of several methods that MSC.EASY5 provides for the integration of the system differential equations. The user may also generate a linearised system model in the vicinity of an equilibrium point, and use these linearised models for linear system analysis and design. In some applications (but not ours), one may not know *a priori* where an appropriate equilibrium point is to be found, and for this reason MSC.EASY5 provides the capability to search for an equilibrium point, starting from a given operating point.

Finally, MSC.EASY5 has a built-in high-level scientific programming environment, the *Matrix Algebra Tool*, which is useful for a variety of purposes, including linear control system analysis and design, analysing and plotting simulation results, and managing the execution of multiple simulation runs (as in a Monte Carlo study, for example).

A conceptual view of our MSC.EASY5 B747-400 model is shown in Fig. 2. One sees that the model is composed of the following main components:

- the Aircraft Model
- a block of Fortran code
- the Sensors submodel
- the instrument landing system (ILS) submodel
- the Flight Director submodel
- a Pilot Model
- the Flight Controls submodel

Brief comments on each of these components are given below, and the reader is referred to Ref. 6 for further details.

The state variables of the Aircraft Model are body x -

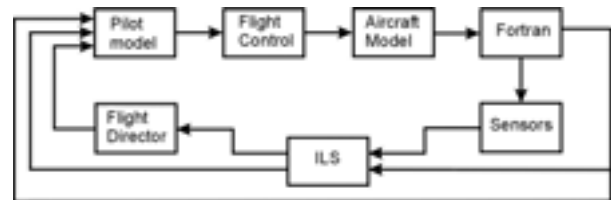

Figure 2. Conceptual block diagram

axis velocity, pitch attitude, pitch rate, angle of attack, altitude rate (the so-called *longitudinal* variables), and sideslip angle, roll attitude, roll rate and yaw rate (the so-called *lateral* variables). The model is linearised around an equilibrium point corresponding to steady, wings-level flight; as is well known, the longitudinal and lateral aerodynamics may in this case be decoupled from one another. One pair of linear models was generated to represent the aeroplane during the approach phase, by trimming the full-fidelity simulation on the descent, and a second pair of linear models was generated to represent the aeroplane during the go-around phase, by trimming the full-fidelity simulation on the climb-out. (Such quadruples of linear models were actually generated for a variety of aeroplane weights, nominal airspeeds, and centre-of-gravity location.) The transition from the approach phase to the go-around phase was implemented by means of a linear interpolation scheme. We also implemented here a detailed model of the B747-400 yaw damper. The Fortran block performs a variety of "top-level" functions, including the calculation of "whole" values of the aerodynamic variables, the calculation of the aeroplane heading angle and the management of the transition from approach to go-around.

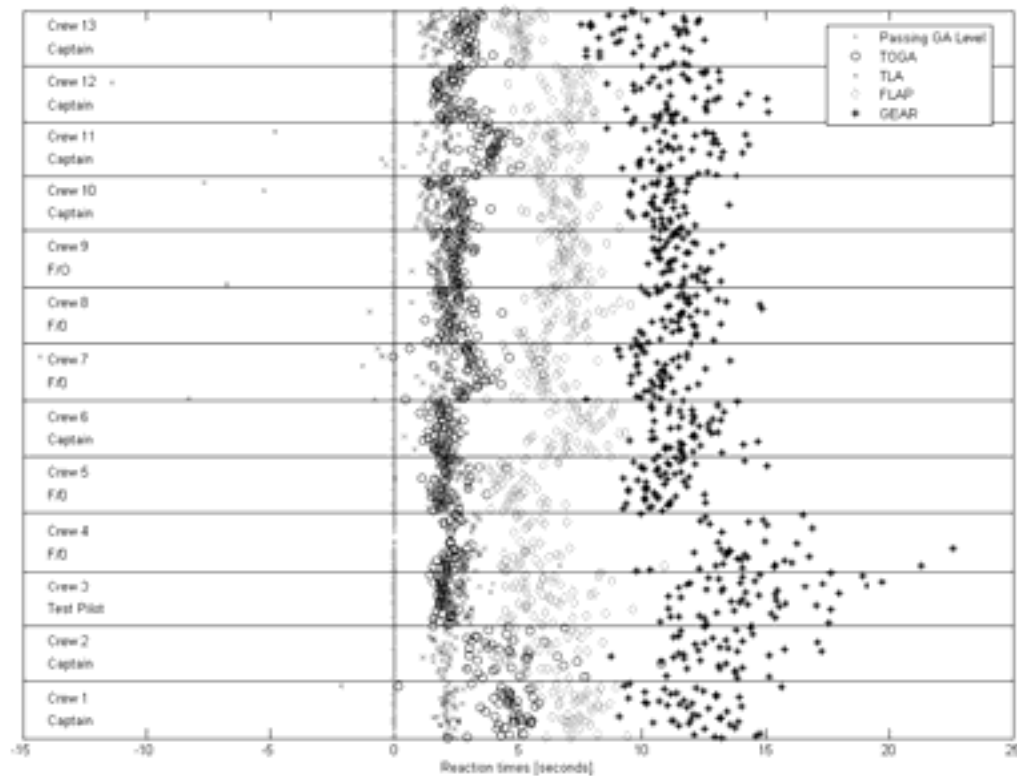

Figure 3. Distribution of pilot reaction times during go-around.

The Sensors submodel and the Flight Director submodel are fairly detailed implementations of the relevant portions of the corresponding components of the full-fidelity simulation.

The ILS model simply computes the deviations of the aeroplane position from the localizer and glideslope beams, as well as computing the aeroplane position relative to a runway-based coordinate system. No attempt was made to implement a realistic model of the ILS errors.

The Flight Controls submodel represents the engines and the control surface actuators, and consists merely of simple first- and second-order lag filters and simple non-linearities. It should be noted that no attempt was made to model the mechanical linkages between the cockpit and the so-called *aft quadrant* where the actuators reside. Therefore, the outputs of the Pilot Model are presented directly to the actuators in the aft quadrant.

Comparisons of the outputs of our MSC.EASY5 model with those of the full-fidelity simulation show a reasonable degree of agreement between the two.

Statistical analysis of flight simulator data

The pilot models, which are described in the subsequent sections, have been developed and calibrated to accurately describe the pilot's skill-based control behaviour during a manually flown precision approach and missed approach. Other control activities during a balked landing, like system management or procedural items are of a more discrete nature and related to higher cognitive functions. According to Rasmussen's theory (see Fig. 1 and Ref. 9) these activities are generated on the rule-based or knowledge-based level, because they are linked to distinctive signs or symbols compared to the continuous stream of signals, which drives the skill-based behaviours. From a statistical analysis of flight data from thirteen air-transport pilots collected in a Boeing B747-400 level D full flight simulator at NASA Ames, a rule-based model layer for procedural items during the visual segment can be derived. This statistical analysis describes for example the onset of the flare as well as the de-crab manoeuvre shortly before touchdown as a function of altitude above aerodrome elevation and experimental factors like wind, gust, visibility and gross weight (Ref. 12). Particular emphasis was put on understanding

variations of pilots' reaction times when executing the go-around manoeuvre after having received a go-around call from the local controller below decision height. These analyses have shown that considerable inter- and intra-individual differences exist between these reaction times and reaction intervals, which are related to external conditions as well as to characteristics of the respective pilot's control behaviour.

The experimental study was carried out in the Crew-Vehicle Systems Research Facility at NASA Ames. Each of the 13 participating pilots performed 48 manual balked landings in random order with 8 full stop landings randomly inserted, according to the experimental protocol. This protocol controlled for the main external factors: 1) height of the go-around call (50, 35, 20, or 10 feet above ground level), 2) crosswind (high versus low), 3) level of gust (high, medium, low), 4) gross weight (high versus low). The research simulator facility recorded continuously 244 aircraft and flight parameters at a 10 to 30 Hertz rate such as position (latitude, longitude), radar altitude, barometric altitude, indicated airspeed, vertical speed, wind direction and speed, flap and gear position, aircraft bank and pitch angles, roll, pitch and rudder pedal commands, engine thrust and so on. In order to measure the go-around reaction times of the pilots, five different events have been determined from the original simulator data profile for each run:

- Go-around Call-out event: equals T_0 , the time when the go-around was called by ATC
- TO/GA event: equals the time when the pilot pushed the TOGA switches
- Thrust Lever Angle event (TLA): equals the time when the thrust lever angle sharply increased,
- Flaps 20 event: equals the time when the flap lever moved into position 20,
- Gear Up event: equals the time when the gear lever moved into the Up position

Fig. 3 illustrates the variation of the individual timing of these events for all thirteen crews across all experimental conditions.

The whole sequence of procedural go-around items lasts on average about 12 seconds from the ATC call to gear-up. The standard deviation is 2.3 seconds. Analysis of variance and multiple regression analyses have shown that the variation of reaction times is only slightly related to the experimental factors gust, weight and go-around call altitude. The crew itself, (to be more concrete, the magnitude and stability of the pilot's control efforts) was identified as the main

source of variance for the reaction times (Ref. 7). Control effort is neither entirely an external nor an internal or individual factor. It reflects the way the pilot controls pitch and roll of the aircraft in different environmental conditions. The rule-based model for the go-around action items includes therefore control effort as an additional (pilot-related) parameter besides the (experimentally controlled)

Table 1. Correlation of reaction times with altitude loss arrest points during balked landings
 (* Significance $\leq 5\%$; ** Significance $\leq 1\%$)

GAC level (ft)	N	% Touch Ground	Average loss (ft)	RT _{INI}	RT _{GEAR}
10	140	72.9	11.34	.069	.394**
20	146	37.7	17.79	.269**	.252**
35	145	30.3	29.12	.069	.284**
50	141	9.9	36.72	.249**	.095

environmental conditions. Other discrete actions like the flare, de-crab or re-crab manoeuvres can be triggered simply by the altitude above the threshold elevation (Ref. 12).

To include a rule-based model layer of the pilot reaction times is deemed particularly important because further analyses have revealed that the altitude loss during the go-around is substantially correlated to how fast the pilot responds to the ATC call. This relation is shown in Table 1 for the different go-around call levels (GAC level, RT_{INI} = reaction time for initial response to the call, RT_{GEAR} = total reaction time until gear up).

QinetiQ pilot model

The QinetiQ pilot models for both pitch and roll control are based on a generic form for a single axis tracking task. This basic model comprises a cycle of

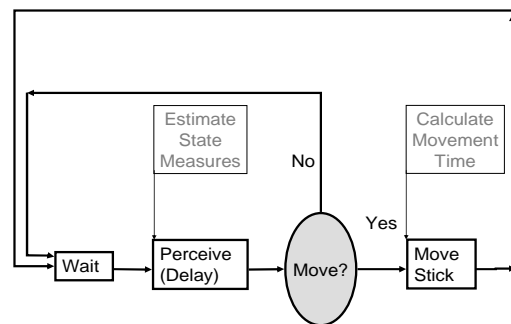

Figure 4. Outline cycle for QinetiQ pilot model pitch and roll

three activities as displayed in Fig. 4. The tasks are indicated by rectangles and the decisions are indicated by ovals. Each task takes a finite time, which is sampled from a specified distribution at each cycle. As shown in Fig. 4, it is assumed that the perceived state of the environment is that pertaining to the start of the perceive task, so that the decision to move the control, represented by the oval, is based on slightly delayed information. Movement time is calculated as the move stick task starts and depends on the size of the control movement.

There are three time parameters in the model: the duration of the “wait” task – *waits* – which represents a short rest after moving the stick or deciding not to move; the duration of the “perceive” task – *delay* – which represents the time taken to assimilate flight director information; the duration of the “move stick” task. Rest time and cognition time are sampled from normal and gamma distributions respectively with expected values given by the parameters *waits* and *delay* respectively and standard deviation of one third of the mean. The time taken to execute a control movement depends on its magnitude and is described below.

The core elements of the model are the perception of required future control position and the decision as to whether to take action to adjust the control. The perception of required future control position is determined as an update to the present control position. It is a simple first order linear controller with a divisor to limit extreme control movements. The adjustment is calculated at the start of the “perceive” task as shown in Fig. 4 and is derived according to Equation (1)

$$adj = \frac{\mu(fderror + \eta.dfderror)}{1 + \gamma.control^2} - \lambda.control \quad (1)$$

where *fderror* is the current flight director command; *dfderror* is the rate of change of flight director command; λ, μ, η are parameters that are to be calibrated; *control* is the current control position; γ is a scale multiplier of the square of the control position.

The parameters μ, λ are gains, while η has the units of time and represents a forward forecast interval. The effect of the divisor on the first term is to damp out extreme excursions. In the second term, if $\lambda = 1$, the adjustment is merely a correction to the

current control position; if $\lambda > 1$, there is a tendency to reduce large excursions with time. The combination of corrections permits some oscillatory behaviour, particularly with respect to pitch, but also tends to damp the oscillations with time. The decision to make a control movement is determined in the “Move” decision box. It is stochastic in that there is a probability that a control movement will be made which depends on the size of the perceived adjustment according to Equation (2)

$$prob(response) = \frac{1}{1 + \exp[-\sigma(|adj| - \tau)]} \quad (2)$$

where *prob(response)* is the probability that a control movement will be made; *adj* is the perceived adjustment calculated in Equation (1); τ is a parameter that is to be calibrated; σ is a scale multiplier of the adjustment.

Detailed investigation of the observed control movements for both pitch and roll collected from the Boeing fixed base simulator indicated that there is not a deterministic relationship between the size of the required movement and the exact timing of the movement. Control movements can occur when no requirement is apparent and pilots can delay adjustments when a correction is demanded. A form of the model was tested in which the probability of movement had a small fixed value if the required correction was less than a threshold value and a larger fixed value if the required movement was above the threshold. The smooth function in equation (2) produced behaviour that was more robust to small disturbances and provided a better fit with observations.

If the decision is that a control movement should be made, the magnitude of the adjustment is calculated at the start of the “Move Stick” task as displayed in Fig. 4. It is derived from the calculated adjustment (Equation (1)) with the addition of a small stochastic error term. If the new control position is within a defined distance from the centre, specified by the parameter *centre*, the control is set to zero. The time taken to make the adjustment is based on Fitts Law, with the time limited to a minimum of 0.1s. To ensure that the movement is not modelled as a single step change at one time, affecting the spectral characteristics of the modelled pilot behaviour, the movement is broken down into a number of discrete steps, all with the same duration and movement. The evidence from examination of

the data is that the pattern of a control movement takes this general linear form.

During a manual flight director approach, the pilot has to be able to see the runway at the decision height, and subsequently rely less on the flight director and more on direct observation of his surroundings. This latter segment of the approach is referred to as the visual segment. Since decision height is approximately 200 feet, the time during which control is modified by direct visual observation is relatively brief, up to 20 seconds. Direct observation of pilots at the Boeing and NASA simulators indicated that they appeared to combine

direct observation of the runway with continued tracking of the flight director. It was therefore decided that the pilot model for the general approach to land should be modified to take account of the visual segment rather than developing a completely separate model.

It was assumed that during the visual segment of the approach, pilots are able to infer position relative to the glide slope by direct observation and so they can use this information to modify their control movement decisions. The alteration in the control movement is only implemented during the visual segment, which is when the aircraft satisfies the following conditions:

- The aircraft is below decision height.
- The go-around procedure hasn't yet been implemented; hence control alterations are only made on the approach to land.
- A randomly generated number between 0 and 1 is found to be less than 0.25, to represent sampling the environment

The pilot model contains an additional term to the control adjustment calculated in the "perceive" task for both pitch and roll, taking account of these conditions.

The pilot model calibration procedure was designed to choose parameter values that minimised the objective function, selected to reflect pilot control behaviour, for a specific pilot/condition combination. This minimisation was undertaken by simulating approaches using a combination of the QinetiQ pilot model and the Boeing full-fidelity B747-400 simulation model. For each approach the objective function was calculated and selected parameters in the pilot model were then adjusted using the Nelder-Mead simplex optimisation procedure and a new approach simulated. When convergence had been attained, the process was terminated and calibration started for a new pilot/condition combination. This procedure is computationally expensive in that a complete approach has to be simulated for each iteration of the optimisation procedure. It has the virtue that stability of the pilot model is guaranteed since unstable behaviour would yield high values of the objective function. It should be noted that as the pilot model is stochastic, the statistical characteristics of the observed pilot behaviour are fitted by this procedure rather than the exact behaviour.

To encapsulate overall pilot behaviour the objective function includes three distinct components for both pitch and roll: a component reflecting control activity; a component reflecting the spectral

Table 2. Pilot and condition effects on calibrated parameter values

Parameter	Significant Effects [†]
Pitch μ	G*
Pitch η	P ***, G**, W*
Pitch λ	P**
Pitch τ	P**
Roll μ	P*
Roll η	
Roll λ	P*, W*
Roll τ	G*

[†]Significant effects: * p<0.05 ** p<0.01 *** p<0.001

Table 3: Variation of Pitch η with external conditions

	Gust 2	Gust 3	Gust 5
Wind 7	1.501	1.455	1.408
Wind 21	1.482	1.386	1.338

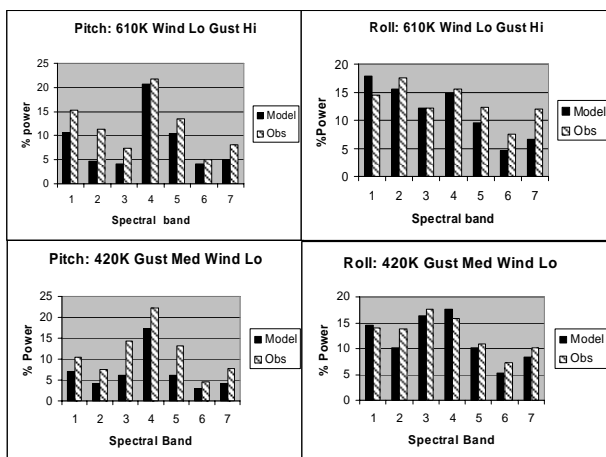

Figure 5. Observed and predicted power spectra of control movements for Pitch and Roll in two conditions

distribution of control movements; a component reflecting deviation from the glide slope in the visual segment. Control activity was calculated as the mean squared deviation of control position from the mean and the contribution to the objective function was calculated as the square of the difference between the logarithm of observed control activity and the logarithm of modelled control activity. The power spectrum for control activity was broken down into 7 wavebands and estimates of the fraction of the power in the 7 wavebands were obtained for both the simulated and observed data and the weighted sum of the squares of the differences was calculated.

The majority of the parameters in the model were estimated from Human Engineering data. A subset comprising 4 key parameters during approach, namely μ , η , λ , τ , were calibrated for both pitch and roll.

Calibration of the pilot model. The calibration is based on the data obtained at NASA Ames, consisting of 13 subjects each completing 12 conditions, varying in weight, wind and gust. All of the simulations were conducted with the inclusion of the visual segment. The Nelder-Mead procedure was used to fit parameters for each of the 156 combinations of pilot and condition, each comprising multiple simulations. Of the 156 calibrations, 141 converged successfully inside the iteration limit. The remaining 15 calibrations failed to converge satisfactorily, and the results summarised below are based on the 141 completely satisfactory calibrations. The variation of the 12 fitted parameters with pilot and experimental condition was investigated using Analysis of Variance (ANOVA). Four factors were identified: Pilot (P - Random Effect), Mass (M - Fixed Effect), Gust pattern (G - Fixed Effect) and Cross wind strength (W - Fixed Effect). A summary of the observed effects is displayed in Table 2.

The majority of the effects in Table 2 are related to differences between the pilots rather than the conditions, as anticipated, although the important differences due to Gust and Mass for Pitch η appear to reflect a change in control strategy according to conditions. The variation between pilots appears considerably more marked for the pitch parameters than for the roll parameters. Within the roll parameters, there is relatively slight indication of variation with the external conditions. From the calibration results, the parameters relating to the

visual segment have poor definition and the method used to determine the values may need further investigation. The detailed variation of Pitch η is displayed in Table 3.

From Table 3 it can be seen that the parameter pitch η tends to decrease with increasing wind and gust. Since the parameter pitch η represents the forward forecast component of the pilot model, this suggests that pilots feel slightly less able to look ahead during turbulent conditions than during steady conditions. This pattern of variation is plausible, and will need to be taken into account in the full simulation study.

Simulated results. Analysis of the control activity and percentage power in the spectral bands indicate a substantial variation between pilots. In addition there are clear main effects of mass and gust. A similar analysis conducted on some results from the simulated descents reveals significant effects in most of the components of condition, condition interactions and subject-condition interactions. The observed and simulated pitch and roll percentage power are displayed for two conditions in Fig. 5. In general, the match between observed and modelled distribution of spectral power is good. For the lower weight aircraft, there is a tendency to underestimate the overall power in the 7 selected spectral bands, although the distribution within the spectrum is reasonably good.

NLR pilot model

The NLR pilot model is based on the descriptive pilot model (Refs. 13, 14) developed to describe pilot's control behaviour in the inner attitude control loop, Fig. 6. A block diagram of the descriptive model is

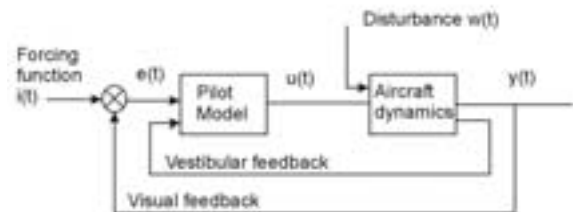

Figure 6. Inner attitude control loop with pilot and aircraft model.

shown in Fig. 7. Sensor dynamics, information processing delay and neuro-motor dynamics have been derived from experimental research and the literature (Refs. 13, 14). The only free parameters of

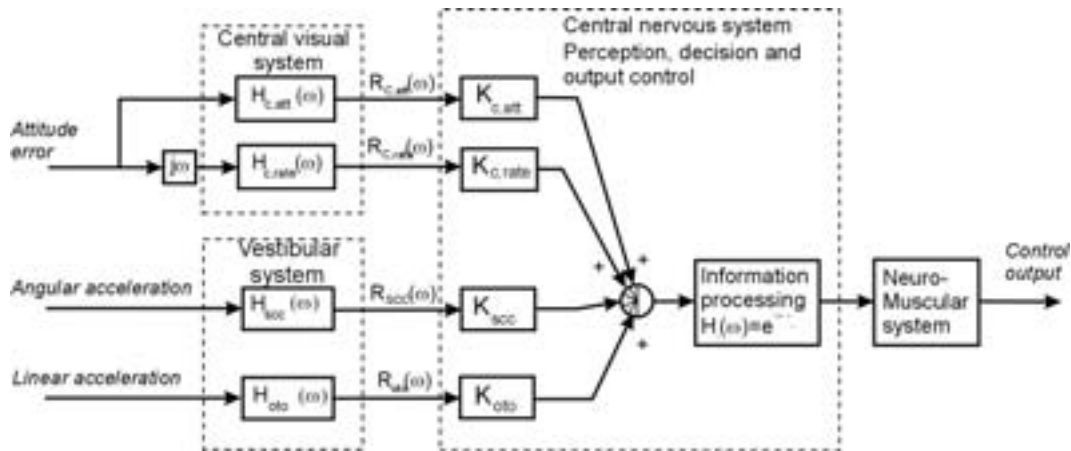

Figure 7. The descriptive pilot model

the model are the gains K_i weighing the sensory outputs R_i . For the inner attitude control loop these parameters can easily be adjusted using an optimisation procedure with the proper control loop characteristics; i.e., aircraft model, task reference $i(t)$ and external disturbance $w(t)$.

When a pilot adjusts his/her behaviour to a certain control task, the first objective is to achieve an acceptable level of tracking performance. If a pilot were to minimise the tracking error alone, his control actions would not take into account the such things as aircraft limitations, structural loads and passenger comfort, for example. In reality, the pilot will normally consider putting more effort into the task as a function of the benefit of the resulting performance improvement, and to the corresponding increase in workload. For these reasons, to bring the workload into account, the mean square of the control signal $u(t)$ and its derivative $\dot{u}(t)$ have been added to the cost function.

There is another consideration: When a pilot tries to improve tracking performance, he will increase his gain. This will result in an increase of the crossover frequency ω_c and a decrease in phase margin ϕ_m . A too high gain will reduce the stability of the control loop. So, the choice of the cost function should aim at the following:

- Good tracking performance
- Effective control effort
- Adequate bandwidth and stability of the control loop as expressed by the crossover frequency and the phase margin.

In order to achieve these goals, the following cost function can be applied.

$$J = \int (e^2 + Q.u^2 + R.\dot{u}^2)$$

By incorporating the control output $u(t)$ and its derivative $\dot{u}(t)$ control effort and its bandwidth are taken into account. The weighing factors Q and R in the cost function depend primarily on the aircraft characteristics, and on the task to be performed.

So, the pilot model adjustment procedure is to first adjust the model to the task based on the above-mentioned principles and after that to compare and fine tune the pilot model control behaviour and performance with the simulation data by adjusting the model parameters. The same holds for the between and within (inter- and intra-) pilot variability. Varying the bandwidth of the pilot model - aircraft open loop by adjusting the model parameters simulates more aggressive or more relaxed pilot behaviour.

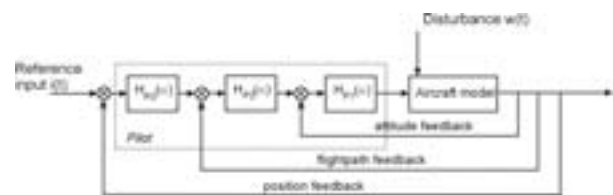

Figure 8. Nested loops with the pilot controlling aircraft position.

It has been shown by several authors (Refs. 15, 16, 17) that the two external disturbances on the control loop, the forcing function $i(t)$ and the disturbance

function $w(t)$ (Fig. 6) have a different influence on pilot's control behaviour especially when motion feedback is present. In the more complicated situation where the pilot controls the aircraft position in a set of nested control loops (Fig. 8) it is of importance to correctly characterise the external disturbances on the control loops when adjusting the pilot model parameters to obtain realistic pilot model behaviour. This dictates careful attention to the set-up of the control loop and external disturbances during the parameter adjustment in the different phases of the bailed landing manoeuvre.

In the particular case of the application of the pilot model to the Bailed Landing Study, it is required to extend the model to simulate the non-linear behaviour of the human operator. In real life, pilots' control behaviour will exhibit inaccuracies and errors (Ref. 18). To take that into account, a remnant signal $n(t)$ (a bandwidth limited noise signal) is added to the model control output, Fig. 9. The remnant characteristics are derived from the literature (Refs. 18, 19, 20) and the remnant signal is added to the model just before the neuro-motor system block in Fig. 7.

One feature of pilots' behaviour in generating control output and related to the non-linear characteristic is that the pilot will often not react immediately to small deviations. Depending on the task this can be simulated by using thresholds to the pilot model input or output. Where necessary, thresholds are applied to bring pilot model output in correspondence with measured pilot control behaviour.

As an example the application of the pilot model (Fig. 7) to altitude control during the visual segment is discussed (Fig. 10). The aircraft pitch attitude control loop is closed by adjusting the pilot model parameters to the task.

To correct for the perceived altitude error e_h the pilot will correct the reference pitch attitude θ_{ref} . By using a pilot gain K_h the vertical deviation e_h is transformed to the reference pitch attitude θ_{ref} .

$$\theta_{ref} = K_h * e_h \quad (4)$$

In this way the outer altitude deviation control loop is closed.

To correct for the influence of a changing headwind which affects the flight path angle, the pilot gain K_h was augmented with an integrator function (PI or Proportional-Integrator controller) to correct for long lasting vertical deviation. The transfer function of the altitude controller is:

$$H_{altitudecontroller}(s) = K_h \frac{s + Clongdev}{s}$$

The influence of headwind on the longitudinal control is thereby taken into account together with thrust control.

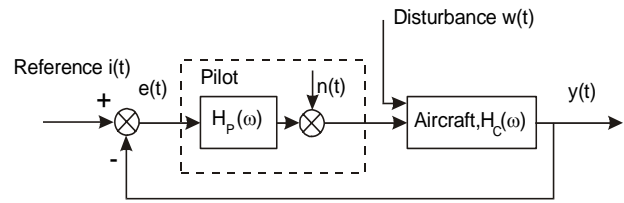

Figure 9. Pilot model with remnant $n(t)$

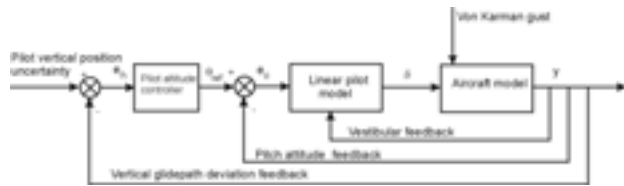

Figure 10. Longitudinal control during the visual segment.

In addition to the remnant, representing a pilot's inaccuracy in generating his control output, the pilot's inaccuracy in perceiving the aircraft's position relative to the intended approach path has to be added to ensure a realistic performance of the pilot model for the present application.

Based on the work of McRuer on pilots' control behaviour, of Clement on pilot control during the manual ILS approach, and of Wewerinke on perception accuracy during the visual segment (Refs. 18, 19, 21, 22), pilots' perception uncertainty of the

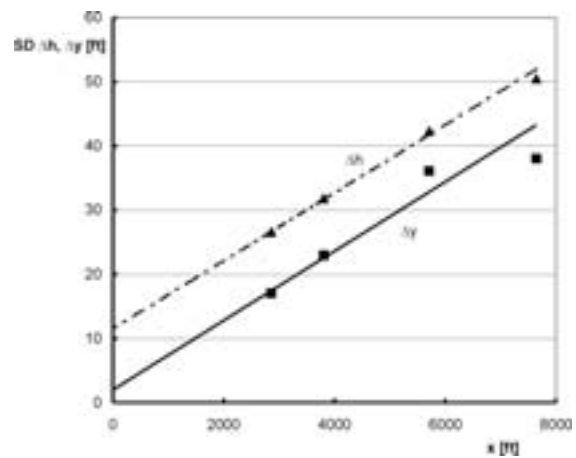

Figure 11. The standard deviation of the perception uncertainty of height Δh and lateral deviation Δy^{10} .

(3)

aircraft position can be modelled. This is modelled by inserting a slowly varying random bias (pilot position uncertainty, Fig. 10) with a magnitude dependent on the distance to the touch down aiming point (Fig. 11).

The bandwidth of the slowly varying uncertainty random signal is 0.075 rad/s for the height uncertainty and 0.05 rad/s for the lateral position uncertainty. Due to the short duration of the visual segment (about 20 s) these random signals have a mean and a variation both decreasing when closing in to the runway. They are based on the results of the manned simulations of the balked landing and on the results of a study on the position perception accuracy by Wewerinke.

Implementation of the pilot model in EASY5. After the pilot model for all segments have been defined the Matlab/Simulink models are converted to EASY5. The parameters in the pilot model are dependent on the following entries:

- Aircraft weight
- Centre-of-gravity location
- Air speed
- Flap setting
- Gear position
- Flight segment
- Weather conditions
- Pilot variability.

The structure of the EASY5 model must be able to handle the schemes for the symmetric and asymmetric models for the 5 segments as a function of aircraft configuration, weather conditions and pilot variability.

In the EASY5 interpolation blocks, linear interpolation is performed for the actual value of longitudinal cg location, pilot variability and air speed, in those parts of the interpolation tables indicated by the actual combination of flap setting and flight segment. These interpolations are performed separately for light, medium, and heavy aircraft weight. Subsequent interpolation in a dedicated FORTRAN block deals with the actual aircraft weight.

The parameters resulting from interpolation are filtered by first-order, low-pass filters, having a time constant of a few seconds, to avoid discontinuous changes in the math pilot output signal.

However, another source of discontinuity still exists, owing to the switching between different lanes, which use different control and feedback variables.

Instead of simple switching, a fading switching method has been introduced. At the switching instant and at the switch output, the present result and the next result are compared. Any discrepancy will generate a bias value, which is added to the next result, making it initially equal to the present one. The bias value is then faded out in a few seconds.

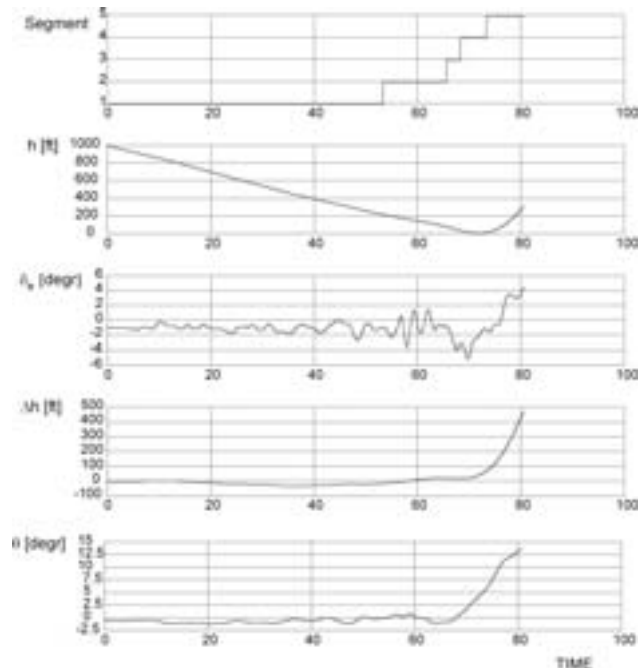

Figure 12. Output of the EASY5 model for the approach/balked landing. Visual segment starts at 200 ft, flare at 60 ft and go-around initiation at 20 ft.

Results. So far, the pilot model structure for longitudinal, lateral and speed/thrust control for the five segments of the balked landing maneuver has been determined. The pilot model parameters have been adjusted for all 36 configurations (aircraft weight, cg, flap setting, and indicated airspeed) and the model and parameters has been implemented in the EASY5 environment. The EASY5 pilot/aircraft model is able to simulate the pilot and aircraft responses for all configurations within the configuration space covered by the 36 configurations. Before each simulation, the aircraft configuration, start of the visual segment, flare and de-crab initiation, go-around initiation, wind and pilot's agility have to be defined. The pilot model in EASY5 runs but has still to be evaluated.

In Fig. 12 an example is given of the output of the EASY5 model and demonstrates that the EASY5 model is running. Results of the EASY5 model presented are based on the state of the art mid June 2005. Pilot model evaluation will be performed first

based on the EASY5 pilot/aircraft model. Fine tuning of the pilot model parameters for the subsequent segments will be based on the results of manned balked landing simulations.

Discussion and conclusions

The Balked Landing Study is a challenging project, which could only be started and successfully performed with the support of the aviation authorities, research institutes and industry. The close co-operation among these partners turned out to be very inspiring, and effective. Still, much remains to be done; in particular, the evaluation of the pilot models for this application. To assure that trustworthy results, acceptable to all involved in the NLA operation, will be obtained, it has to be shown that the pilot model tracking performance statistically equals the tracking performance in real life operation. The highly qualified and independent Central Aero-Hydrodynamics Institute (TsAGI) in Moscow has been invited to formulate and execute a plan for this evaluation.

So far, the pilot model development environment (EASY5) performs adequately to support the pilot model development, both the model structure and the initial calibrations. The final calibrations of the pilot models, however, have to be performed in combination with the high-fidelity B747-400 IAC model, which will also be used for the future Monte Carlo simulations. These simulations will be controlled by a scenario file, which configures the aircraft configuration, weather conditions and pilot variability. The results of the statistical analysis on pilot's rule-based behaviour as discussed will also be modelled in the scenario files to adjust the pilot models for each simulation.

The two pilot models are based on fundamentally different descriptions of a pilot's control behaviour. The QinetiQ pilot model is based on a repertoire of discrete tasks that is able to predict human workload and performance, based on a model of human tracking behaviour developed in the Integrated Performance Modelling Environment (IPME). The NLR pilot model is based on control engineering and is a linear model with visual and motion feedback, extended with stochastic disturbances. Also the initial adjustment of the pilot model parameters is different. While the QinetiQ model parameters are adjusted based on the available simulation database of the balked landing manoeuvre, the NLR model

parameters are adjusted for each segment of the manoeuvre to the control task. Final adjustment of both models will be based on the statistical results from the simulation database.

The present available data base from the manned simulations of the balked landing manoeuvre cover quite a range of aircraft configurations, weather conditions and pilot variability. However, the question has to be raised whether this database is sufficient to support the final results of the Balked Landing Study. This question will be part of the final pilot model evaluation.

The application of pilot models in this study to obtain reliable statistical information on pilots' tracking performance during the balked landing may turn out to be a breakthrough in the support of aircraft operation and the required issuing of aviation rules.

Acknowledgement

The implementation of the pilot model development environment, the statistical analysis, and the pilot model development described in this paper have been carried out under various contracts with the FAA, Eurocontrol, the Civil Aviation Authority Netherlands (IVW) and the Boeing Company. The authors of the paper would like to express their gratitude for the commitment and sponsorship of these organizations, which provided the opportunity to carry out this work as part of a larger undertaking.

The models have been developed in close cooperation with The Boeing Company, which provided the aeroplane and avionics system models. Special thanks go to Jerry Robinson for organizing the cooperation among Boeing, FAA, QinetiQ, NLR, and AMS Consult.

References

1. Robinson, J.J., L.A. Boniface, E.Lassooij, D.P.Pate, and R. Putters. Impact of pilot modeling applications to the development of ICAO standards for new larger aeroplanes. Royal Aeronautical Society Conference on: Civil & Military Flight Simulator Qualification. Time for an upgrade? London November 9 – 10, 2005.
2. Anderson, D, J. Robinson, J. Towler, D. Pate, S. Barnes, L. Boniface, D. Lankford, G. Legarreta, G. McCartor, E. Lassooij, E. Bailey, and R. Putters (2005). "Simulation modeling in the development of flight procedures and aerodrome standards". *AIAA Modeling and Simulation Technologies Conference*,

- San Francisco, CA. August 15-18, 2005. AIAA 2005-5879.
3. Barnes, S, G. Lankford, D. McCartor, and S. Ladecky (2005). "The new FAA flight simulation laboratory's impact on flight procedure design". *AIAA Modeling and Simulation Technologies Conference, San Francisco, CA.* August 15-18, 2005. AIAA 2005-5880.
 4. Belyavin, A., A.Woodward, G. Robel, and J. Woolworth (2005). "Development of a novel model of pilot control behavior in bailed landings". *AIAA Modeling and Simulation Technologies Conference, San Francisco, CA.* August 15-18, 2005. AIAA 2005-5878.
 5. Hosman, R., J. Schuring, and P. van der Geest (2005). Pilot model development for the manual bailed landing maneuver. *AIAA Modeling and Simulation Technologies Conference.* San Francisco, CA. August 15-19 2005. AIAA-2005-5884.
 6. Nguyen, D., G. Robel, J. Robinson, J. Towler, and J. Woolworth (2005). "Implementation of a large airplane simulation model to support pilot model development". *AIAA Modeling and Simulation Technologies Conference, San Francisco, August 15-18, 2005.* AIAA 2005-5882.
 7. Hörmann, H.J., P. van den Berg, J. Peixato, J. Robinson, T. Rager, A. Belyavin, and R.Hosman (2005). "Analysis of pilot control behavior during bailed landing maneuvers". *AIAA Modeling and Simulation Technologies Conference, San Francisco, CA.* August 15-18, 2005. AIAA 2005-5881.
 8. Yaroshevskiy, V.A., A.V. Bobylev, V.G. Nekrasov, A.N. Stepanenko, H.J. Hörmann, J. Peixoto, G. Robel and J. Robinson (2005). "A Validation Plan for Pilot Models Developed for New Larger Airplanes". *AIAA Modeling and Simulation Technologies Conference, San Francisco, CA.* August 15-18, 2005. AIAA 2005-5883.
 9. Rasmussen, J. (1983). "Skills, Rules, and Knowledge; Signals, Signs, and Symbols, and Other Distinctions in Human Performance Models". *IEEE Transactions on Systems, Man and Cybernetics*, Vol. SMC-13, No. 3, May/June 1983.
 10. Hosman, R.J.A.W., J. Schuring, and L.J.J.Erkelen (2004). "A pilot model developed for investigation the bailed landing maneuver". National Aerospace Laboratory NLR, Amsterdam. Contractory Report NLR-CR-2003-637.
 11. Bentley, M., and A.J. Belyavin (2004). QinetiQ Pilot Model: Initial Development. QinetiQ/KI/CHS/TR040389.
 12. Hörmann, H.J. (2005). "Bailed Landing Study, Visual segment pilot activities and model requirements". Boeing Research & Technology EuropeS.L. Madrid, Spain.
 13. Hosman, Ruud (1996). "Pilot's perception and control of aircraft motions". Ph. D. Thesis. Delft University of Technology. Delftse Universitaire Pers, Delft, the Netherlands.
 14. Hosman, Ruud and Henk Stassen (1999). "Pilot's perception in the control of aircraft motions". *Control Engineering Practices*. Vol. 7, No. 11, pp. 1421-1428, 1999.
 15. Stapleford, R.L., R.A. Peters, and F.R. Alex, (1969). "Experiments and a model for pilot dynamics with visual and motion inputs". NASA CR-1325.
 16. Levison, W.H., and A.M. Junker (1977). "A model for pilot's use of motion cues in roll-axis tracking tasks". Bolt Beranek and Newman Inc. Report No. 3528, Cambridge, Ma.
 17. Hosman, R.J.A.W., S.K. Advani and N. Haeck (2005a). "Integrated design of the motion cueing system for a Wright Flyer Simulator". *AIAA Journal of Guidance, Control and Dynamics*. Vol 28, nr. 1, pp 43-5
 18. McRuer, D.T., D.Graham, E.S. Krendel, and W. Reisener (1965). "Human Pilot Dynamics in Compensatory Systems. Theory, Models, and Experiments with Controlled Element and Forcing Function Variations". AFFDL-TR-65-15, Wright Patterson AFB, Ohio.
 19. Clement, W.F., H.R. Jex, and D. Graham (1968). "Application of system analysis theory for manual control displays to aircraft instrument landing". *Forth Annual NASA University Conference on Manual Control*. NASA SP-192.
 20. Steurs, M., M.Mulder, R.van Paassen (2004). A cybernetic approach to assess flight simulator fidelity. AIAA Modeling and Simulation Technologies Conference, Providence, RI. August 16-19 2005. AIAA 2004-5442.
 21. Wewerinke, P.H. (1978). "Visual scene perception process involved in the manual approach". National Aerospace Laboratory (NLR), Amsterdam. NLR TR 78130 U.
 22. Wewerinke, P.H. (1980). "The effect of visual information on the manual approach and landing". National Aerospace Laboratory (NLR), Amsterdam. NLR TR 80055 U.